



Environmental Health and Safety
Biological Safety Program
Guidelines for Biological Safety Cabinets

Date Revised: August 2024

General: This document defines guidelines for the selection, installation, relocation, use, decontamination and disposal of biological safety cabinets (BSCs) at UTHealth Houston.

Description:

All standards for the use of biological safety cabinets (BSCs) set forth in NSF/ANSI 49-*Biosafety Cabinetry: Design, Construction, Performance, and Field Certification* (2022) shall be followed. This document describes additional recommendations and procedures for the purchase, installation, use, decontamination, and disposal of such equipment at UTHealth Houston. Please contact Environmental Health and Safety (EHS) at 713-500-8100 for any questions regarding the following information.

There are currently three classes of BSCs which are designed to provide personal, product, and environmental protection when working with potentially infectious biological agents:

Class I: A ventilated cabinet for personnel and environmental protection. Air flows inward, away from the operator, and is exhausted to the atmosphere after filtration through a HEPA filter. There is no downflow air or recirculation of inflow air such as in Class II cabinets.

Class I cabinets are suitable for work where no product protection is required, due to the inflow air being drawn across the work surface prior to exiting the cabinet via the exhaust. Class I cabinets may be used for work with volatile toxic chemicals and volatile radionuclides required as adjuncts to microbiological studies, if they are configured with a ducted exhaust.

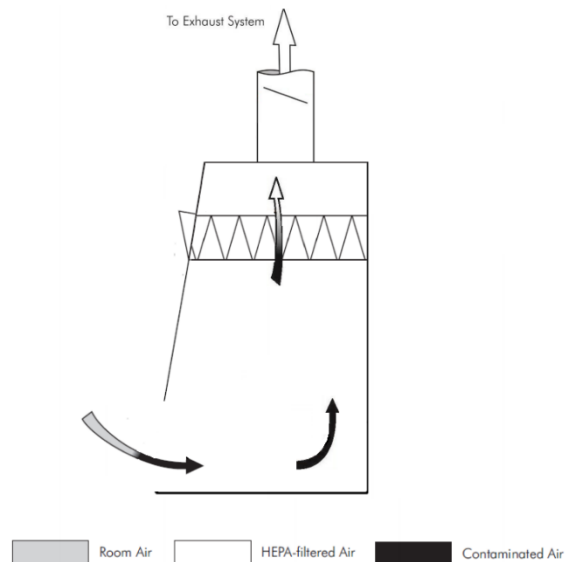

Class II (Types A1, A2, B1, B2, and C1): A ventilated cabinet for personnel, product, and environmental protection having an open front with inward airflow for personnel protection, downward HEPA filtered laminar airflow for product protection, and HEPA filtered exhausted air for environmental protection.

NOTE – When toxic chemicals or radionuclides are used as adjuncts to biological studies or pharmaceutical work, Class II cabinets designed and constructed for this purpose should be used.

Class II Type A1 cabinets (formerly designated Type A)

- maintain minimum average inflow velocity of 75 ft/min (0.38 m/s) through the work access opening
- have HEPA filtered downflow air that is a portion of the mixed downflow and inflow air from a common plenum (i.e., a plenum from which a portion of the air is exhausted from the cabinet and the remainder supplied to the work area)
- may exhaust HEPA filtered air back into the laboratory or to the environment through an exhaust canopy
- may have positive pressure contaminated ducts and plenums that are not surrounded by negative pressure plenums

Class II Type A1 cabinets are not suitable for work with volatile toxic chemicals and volatile radionuclides.

Class II Type A2 cabinets (formerly designated Type B3)

- maintain a minimum average inflow velocity of 100 ft/min (0.5 m/s) through the work access opening
- have HEPA filtered downflow air that is a portion of the mixed downflow and inflow air from a common exhaust plenum
- may exhaust HEPA filtered air back into the laboratory or to the environment through an exhaust canopy
- have all biologically contaminated ducts and plenums under negative pressure or surrounded by negative pressure ducts and plenums

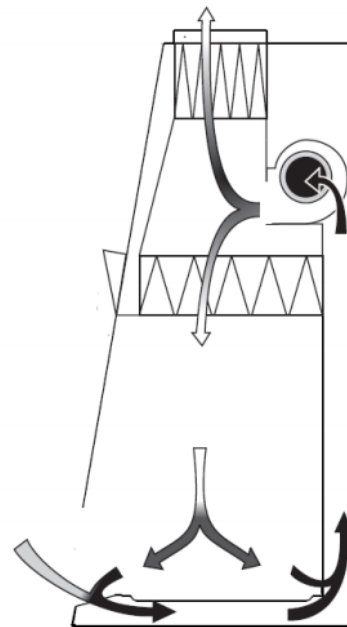

Benchtop Configuration

Room Air HEPA-filtered Air Contaminated Air

Class II Type A2 cabinets used for work with minute quantities of volatile toxic chemicals and tracer amounts of volatile radionuclides required as an adjunct to microbiological studies must be exhausted through properly functioning exhaust canopies.

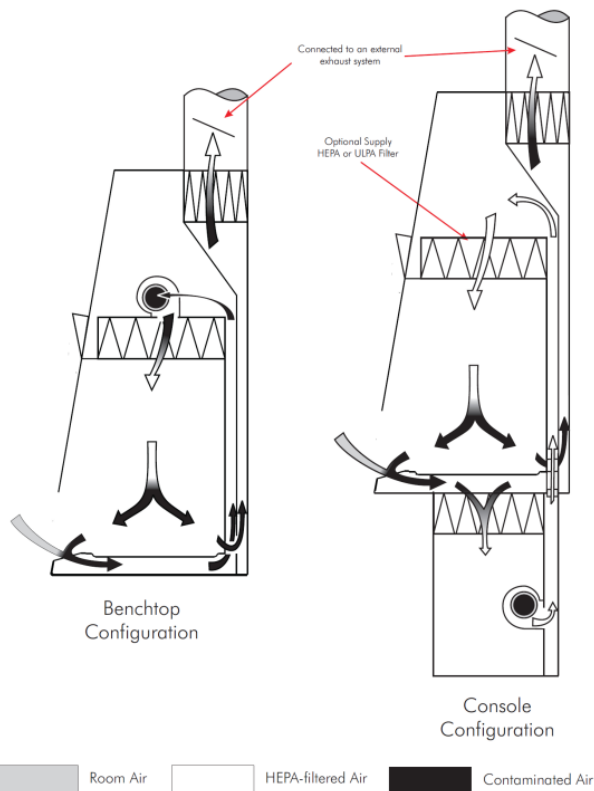

Class II Type B1 cabinets

- maintain a minimum average inflow velocity of 100 ft/min (0.5 m/s) through the work access opening
- have HEPA filtered downflow air composed largely of uncontaminated recirculated inflow air
- exhaust most of the contaminated downflow air through a dedicated duct exhausted to the atmosphere after passing through a HEPA filter
- have all biologically contaminated ducts and plenums under negative pressure or surrounded by negative pressure ducts and plenums

Class II Type B1 cabinets may be used for work treated with minute quantities of volatile toxic chemicals and tracer amounts of volatile radionuclides required as an adjunct to microbiological studies if work is done in the direct exhausted portion of the cabinet, or if the chemicals or radionuclides will not interfere with the work when recirculated in the downflow air.

Class II Type B2 cabinets

(sometimes referred to as "total exhaust")

- maintain a minimum average inflow velocity of 100 ft/min (0.5 m/s) through the work access opening
- have HEPA filtered downflow air drawn from the laboratory or the outside air (i.e., downflow air is not recirculated from the cabinet exhaust air)
- exhaust all inflow and downflow air to the atmosphere after filtration through a HEPA filter without recirculation in the cabinet or return to the laboratory
- have all contaminated ducts and plenums under negative pressure or surrounded by directly exhausted (non-recirculated through the work area) negative pressure ducts and plenums

Class II Type B2 cabinets may be used for work with volatile toxic chemicals and volatile radionuclides required as adjuncts to microbiological studies.

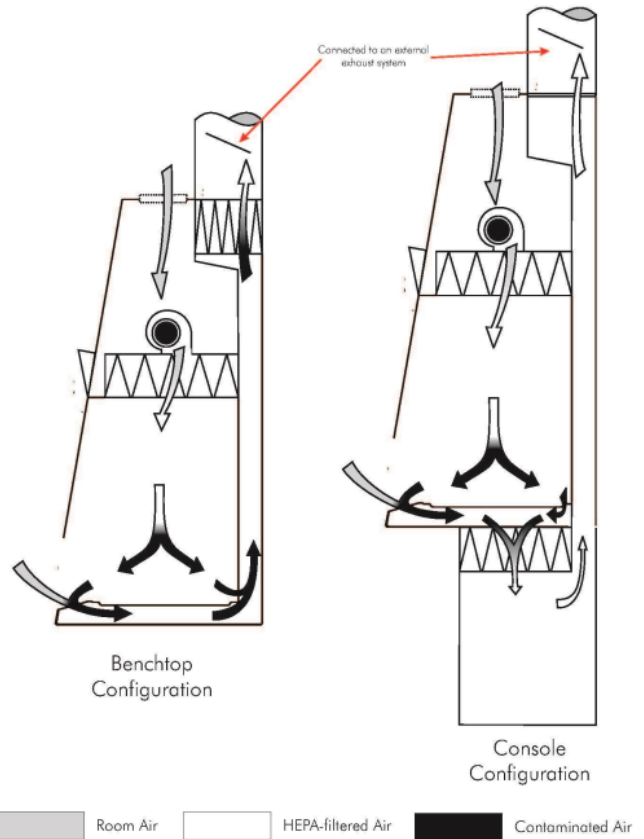

Class II Type C1 cabinets

- maintain a minimum average inflow velocity of 100 ft/min (0.5 m/s) through the work access opening
- depending on configuration, can exhaust the contaminated downflow air through a dedicated duct exhausted to the atmosphere after passing through a HEPA filter or exhaust HEPA filtered air back into the laboratory or to the environment through an exhaust canopy
- have HEPA filtered downflow air composed largely of uncontaminated recirculated inflow air, similar to a type B1 cabinet
- the internal exhaust motor can run for up to 5 minutes in the event of an exhaust failure, to protect materials inside the cabinet

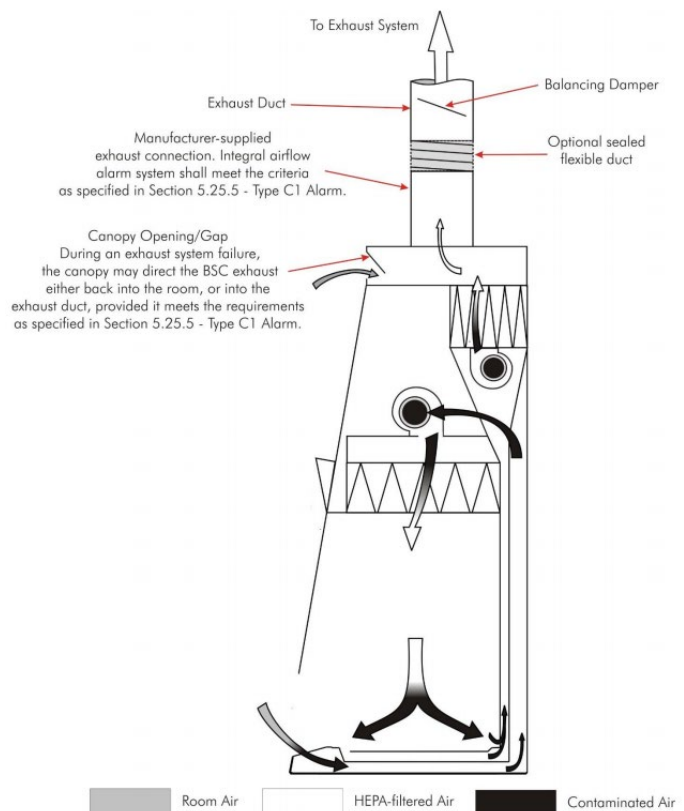

Class II Type C1 cabinets may be used for work treated with minute quantities of volatile toxic chemicals and tracer amounts of volatile radionuclides required as an adjunct to microbiological studies if the cabinet is connected to exhaust duct, but not when setup to exhaust back into the room.

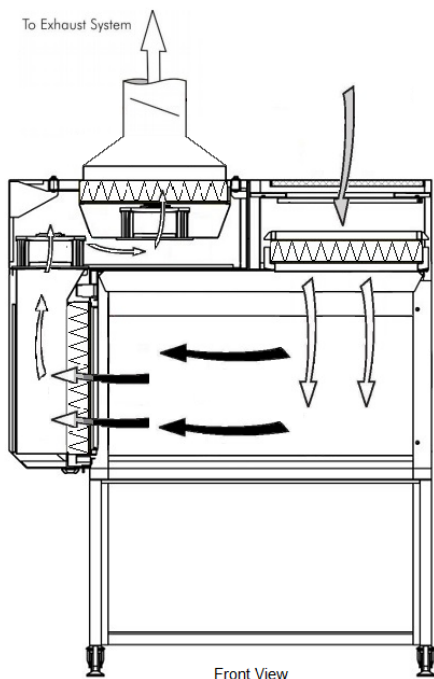

Class III:

A totally enclosed, ventilated cabinet of gas-tight construction. Operations in the cabinet are conducted through attached rubber gloves. Materials can be brought into or out of the cabinet via a pass-through autoclave and/or disinfectant dunk tank.

The cabinet is maintained under negative air pressure of at least 0.50 inches w.g. (120 Pa). Downflow air is drawn into the cabinet through HEPA filters. The exhaust air is treated by double HEPA filtration or by HEPA filtration and incineration.

BSC Class, Type	Face Velocity (ft/min)	Airflow Pattern	Applications	
			Nonvolatile Toxic Chemicals and Radionuclides	Volatile Toxic Chemicals and Radionuclides
I	75	In at front; exhausted through HEPA to the outside or into the room through HEPA	YES	YES (if exhausted outdoors) ^{1,2}
II, A1	75	70% recirculated to the cabinet work area through HEPA; 30% balance can be exhausted through HEPA back into the room or to the outside through a thimble unit	YES (minute amounts)	NO
II, A2	100	Same as II, A1, but plenums are under negative pressure to room; exhaust air is thimble-ducted to the outside through a HEPA filter	YES	YES (minute amounts) ^{1,2}
II, B1	100	Exhaust cabinet air must pass through a dedicated duct to the outside through a HEPA filter	YES	YES (minute amounts) ^{1,2}
II, B2	100	No recirculation; total exhaust to the outside through hard-duct and a HEPA filter	YES	YES (small amounts) ^{1,2}
II, C1	100	Exhaust cabinet air must pass through a HEPA filter before being exhausted to the outside through a duct, or back into the room through canopy.	YES	YES (minute amounts) ^{1,2}
III	N/A	Supply air inlets and hard-duct exhausted to outside through two HEPA filters in series	YES	YES (small amounts) ^{1,2}

¹Installation may require a special duct to the outside, an in-line charcoal filter, and a spark proof (explosion-proof) motor and other electrical components in the cabinet. Discharge of a Class I or Class II, Type A2 cabinet into a room should not occur if volatile chemicals are used.

²In no instance should the chemical concentration approach the lower explosion limits of the compounds.

Adapted from The National Academies; Prudent Practices in the Laboratory (2011)

Selection:

It is essential that the proper type of biological safety cabinet be selected to ensure adequate personal, product, and environmental protection. Please contact EHS for consultation on the appropriate type of cabinet which will be sufficient for the proposed work to be conducted within the unit.

Often times biological safety cabinets are available from surplus, which can be a cost effective method of obtaining a cabinet. Contact Capital Assets Management directly to determine if a specific cabinet type is available prior to purchasing a new unit.

Installation:

When obtaining a biological safety cabinet, it is essential to determine the product specifications and requirements, such as electrical and plumbing (e.g. vacuum). Facilities Planning and Engineering must be contacted in advance to determine the specific BSC installation requirements and if the laboratory has the necessary infrastructure to support the use of the cabinet. This is particularly important when the BSC is to be connected to the building's exhaust system or be placed on emergency power supply.

Consider the following in planning the location of a biological safety cabinet: the unit should be placed away from potential air currents which could disrupt the air flow in and around the BSC. Potential air currents can be produced by movement in walkway aisles, swift or quick movements by arms while working in the BSC, or from the motion created by the opening and closing of doors. Additionally, BSCs should not be located in the direct path of air supply vents which may disturb the unit's air flow.

Location "A" shows the preferred location. Location "B" is an alternate location. The air supply register(s) above or near the cabinet's location should be redirected away from the cabinet face.

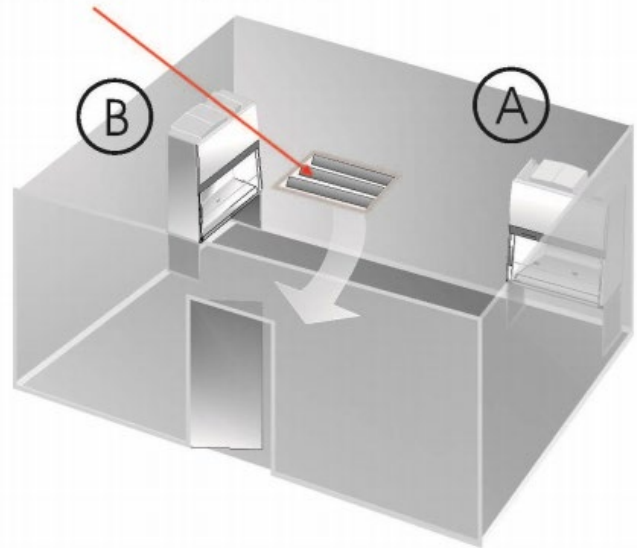

As a safety precaution, no combustible gas is allowed to be plumbed into a biological safety cabinet at UTHealth Houston. Open flames should never be used within a cabinet, as this practice creates a fire hazard and can also disturb air flow currents within the unit. An alternative for open flames in the BSC are products such as “bacteriocinerators”. Electrical outlets for the unit should be located above the biological safety cabinet or in another accessible location so that the unit does not impede access to the outlet. This will aid in routine maintenance activities and cabinet certification processes. In some cases emergency power should be considered.

HEPA Filters:

HEPA filters should be installed properly into a unit only by an appropriately trained and qualified contractor. Routine surveillance of the HEPA filters should be performed to ensure filter integrity, examine filter loading and extent of useful life. If necessary, HEPA filters should only be removed by an appropriately trained and qualified contractor. HEPA filters should be decontaminated prior to removal and/or BSC should be decontaminated prior to recertification or opening the casing of the cabinet if potentially infectious materials have been in the BSC. HEPA filters should be removed using a bag out technique and carried out with the contractor for disposal.

Proper Usage:

Familiarize yourself with the BSC before use by consulting the user's manual. While BSCs are designed to provide safe work environments some work habits can greatly affect the security they provide. Before entry into a BSC, the blowers should be turned on and run for approximately 5 minutes in order to allow for the proper pressures to build up. Steps to ensure safe use of a BSC include:

- Wear a lab coat and appropriate gloves that fit over the cuffs of the coat
- Gather all needed materials at once to reduce the number of entries into the BSC
- Wipe all materials down with 70% ethanol prior to entry into BSC
- Arrange work space inside of BSC into clean and contaminated zones. Work from clean to dirty
- Place aerosol generating equipment in the rear of the cabinet
- Place materials in the BSC in such a way that they do not block grilles, disturbing airflow

- Upon completion of work, disinfect all materials exiting the BSC as well as the surfaces inside of the BSC

Should you experience a power outage while working within the BSC, be sure to remain still and wait for emergency power to respond. If your unit doesn't receive emergency power, slowly withdraw your hands out of the unit and lower the sash. Then proceed to disinfect your hands and the outside of the unit with an appropriate solution.

Relocation of Biological Safety Cabinets:

If a biological safety cabinet is to be moved within a building, to another building location, or to surplus, certain steps must be taken to ensure that potentially infectious biological agents do not remain in the unit. Contact EHS prior to relocation of a biological safety cabinet to perform a risk assessment and determine the actions required to complete the move. Laboratories may be required to have the biological safety cabinet properly decontaminated by an appropriately trained and qualified contractor prior to relocation at the laboratories expense. HEPA filters may not be required to be removed if a thorough decontamination (e.g. formaldehyde, vapor phase hydrogen peroxide) is performed by a certified technician, however this determination must be made on a case by case basis through the performance of a risk assessment by EHS.

NOTE: A *CATER* inspection must be performed by EHS prior to relocation to the surplus warehouse.

Certification and Providers

UTHealth Houston requires that BSCs be certified at minimum annually to NSF 49 Standard to ensure the proper functioning of the unit. A list of qualified providers can be obtained by contacting the EHS Biological Safety Program at 713-500-8170 or by visiting the NSF website at <http://www.nsf.org/services/by-industry/pharma-biotech/biosafety-cabinetry/nsf-ansi-49-biosafety-cabinetry-certification>

References:

The National Academies, *Prudent Practices in the Laboratory: Handling and Management of Chemical Hazards, Updated Version*, March 2011.

NSF/ANSI 49, *Biosafety Cabinetry: Design, Construction, Performance, and Field Certification*, 2022.

United States Department of Health and Human Services, *Biosafety in Microbiological and Biomedical Laboratories* (6th edition), June 2020.